

SBI
SWEDEN



Engaging Visitors



**SHOPPING
CENTER
EDITION**

**Fun
Interactive
Educational**

2025

About Us

Attractions for Children

Since the early 1980s, SBI Sweden has been a leading supplier of reliable interactive kiddie rides, specializing in top-quality miniature vehicles, including cars, trucks, tractors, boats, and construction-themed machinery for children.

Our dedication to customer satisfaction, top-quality products, and outstanding after-sales support is valued by a diverse clientele, from large amusement parks to small family farms. We prioritize innovation, genuine design, and craftsmanship while maintaining a global reach with a familial approach. Our battery-powered

products, made in Sweden, emphasize autonomy, quality, and durability, offering interactive experiences for children. We serve a broad range of sectors, including LEGOLAND and Universal Studios, and customize products for kids aged 3-11. If you're not yet a customer, contact us to see how we can support your business.

We Put Kids in the Front Seat

FUN



The new World of Volvo opened in Gothenburg during 2024. Our products are featured to enhance the experience for the visitors.

WORLD OF VOLVO

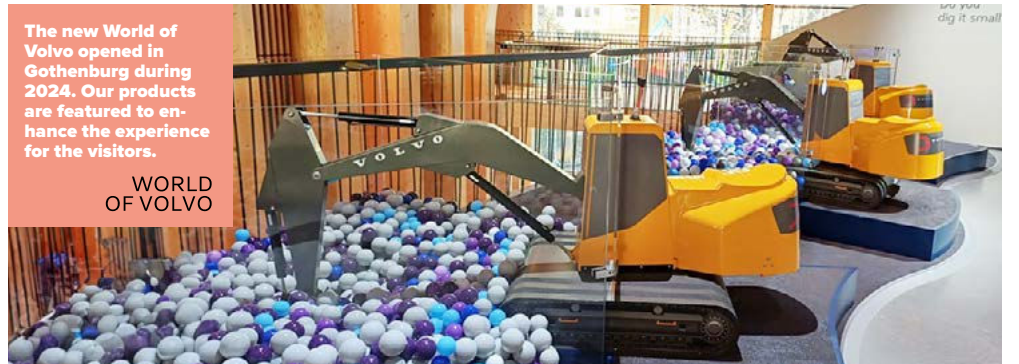

EDUCATIONAL

Our Ferrari Spider, developed with Ferrari, has been delivered to Ferrari World in Dubai.



LEGOLAND Florida Resort's boats operate year-round, thanks to the state's warm climate.



INTERACTIVE

OUR TEAM
At SBI, our work thrives on attention to detail and strong, friendly relationships. Our talented team, passionate about bringing joy to children, is our greatest asset. We pride ourselves on our specialization and close customer connections.

JAPAN

OCEANIA

About Us

Why work with Us?

Choose us as your manufacturer and supplier of amusement products for playlands, theme parks, campgrounds, and shopping centers

Our commitment to quality ensures that every product is designed with safety and fun in mind, meeting the highest standards for durability and enjoyment. With a track record of reliability and innovation, we provide tailored solutions that enhance the experience for children while supporting your operational goals. Partner with us to deliver exceptional, memorable experiences that keep families coming back. Our

extensive industry expertise ensures high-quality products designed for safety, durability, and enjoyment. We emphasize long-term collaboration, providing comprehensive service and reliable spare parts to support your needs and maximize your return on investment. Partner with us to deliver exceptional experiences for children while enjoying ongoing support and peace of mind.

Our products in a French park at Les Baux-de-Breteuil, Normandie.



Educational activity is a highlight at LEGOLAND California, offering both fun and learning in one exciting package.

LEGOLAND
CALIFORNIA



Our model FH16 features custom-designed décor in collaboration with the client's sponsor, Volvo. The trailer was created based on the client's specifications.

Hunderfossen
EVENTPARK

Work with Us!

With 40 years of experience, SBI delivers top-quality products and exceptional customer service. Serving clients in 60 countries and holding an AAA rating, we offer minimal maintenance, low operational costs, and prompt support. Our proven expertise and long-term relationships with renowned references make us a trusted partner. Let our competence benefit your business.

- 40 years of experience
- Top-quality products
- Excellent customer service
- Globally recognized with clients in 60 countries
- AAA rated
- Minimal maintenance and operational costs
- Prompt support
- Reliable partner with long-term, stable relationships
- Many well-known references

Certifications and Compliance. We proudly hold several key certifications, demonstrating our commitment to top industry standards and regulatory excellence.



ISO 9002: Standard focused on quality management systems. It outlines requirements for ensuring consistent product quality and customer satisfaction.



ISO 14001: This standard specifies requirements for an effective environmental management system (EMS). It helps organizations improve their environmental performance and comply with regulations.



EN 1176: This European standard sets safety requirements for playground equipment and surfacing. It aims to ensure the safety of children using playground facilities.



EN 1177: This standard specifies the impact attenuation of playground surfaces to reduce the risk of injury. It provides guidelines for testing the safety performance of surfaces under playground equipment.



Some of our Valued Customers:

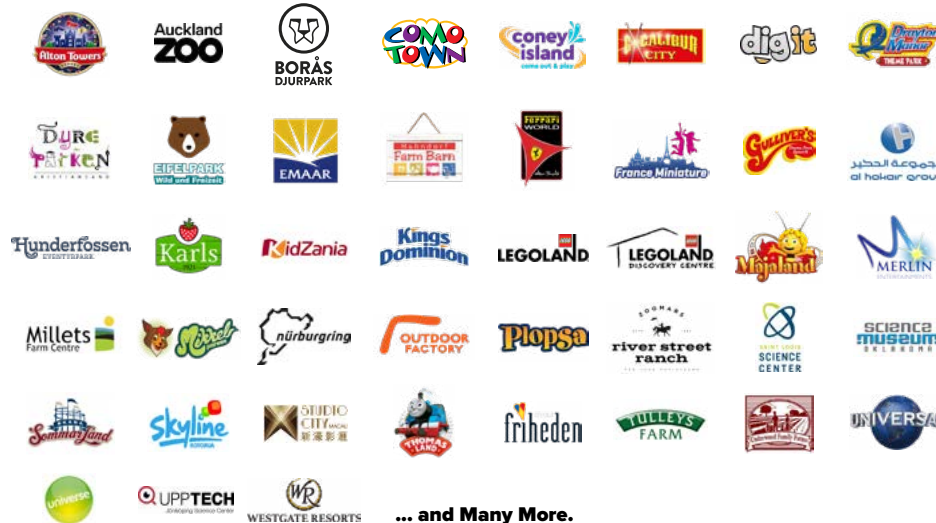

... and Many More.

Shopping Center

Add a Kids' Destination to Your Shopping Center

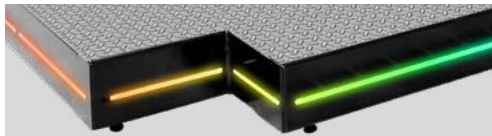

Light and Sound

Theme Design

Door



At Asecs shopping centers in Sweden: a safe, self-supervised attraction for children, offering fun and peace of mind for parents.



Payment system

Safety protection

Boxes



Boost Your Shopping Center's Appeal with Construction Zone. Looking to attract families and increase foot traffic? Introducing Construction Zone—a cutting-edge, fully automated attraction that entertains children and enhances your center's appeal.

Construction Zone offers more than just an attraction—it's a strategic tool to increase your center's popularity. It entertains children and encourages parents to shop longer, leading to higher customer satisfaction and increased tenant sales.

Our unique attraction draws families, making your shopping center a top choice for both parents and kids. Designed to be staff-free with digital payments and automated monitoring, Construction Zone is a low-maintenance addition with a payback period of under a year. It can also be customized with your branding to match your center's aesthetic.

Transform your shopping center into a family destination with Construction Zone. Contact us today to learn more and start attracting more visitors.

Construction Zone



SBI CAGE SYSTEM

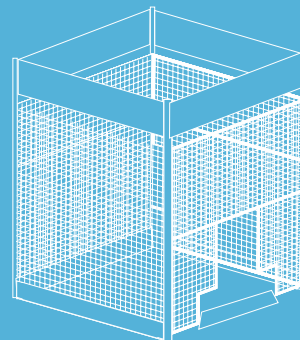
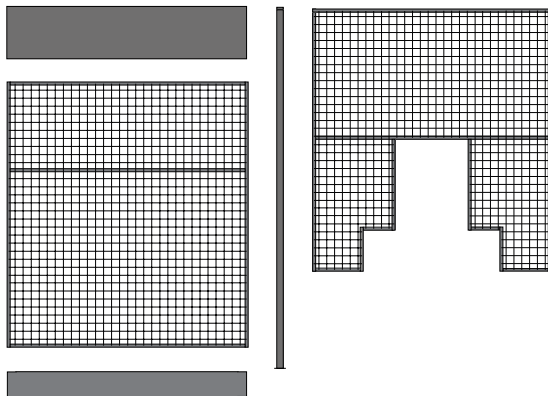

MEASUREMENTS:

L 1600 mm, W 1640 mm, H 2200 mm.
L 5 ft 3 in, W 5 ft 5 in, H 7 ft 3 in.

TECHNICAL SPECIFICATIONS SBI Cage System

Fully customizable with a range of theming options to perfectly fit your location.

- Outdoors: Galvanized Steel Construction
- Indoors: Steel Construction
- Black Powder coating
- Easy to mount
- Perfect for Mini Tower Crane and Mini Digger / Grabber.
- The swing radius of the Mini Digger / Grabber is adjusted to fit in the cage.
- Heavy duty adjustable platforms with LED Neon lights.

This safety cage is specifically engineered to allow machinery to operate safely without requiring constant staff supervision. It adheres to all relevant regulatory standards, ensuring the highest level of protection. Beyond its functional benefits, the cage is designed to enhance the "Construction Zone" atmosphere, adding an authentic industrial feel to the environment. The structure also provides ample space for signage, making it an ideal platform for displaying important messages or promotional content, further integrating safety with effective communication.



Enhance the Experience with Custom Signage

To elevate the optical impact, we offer signage that enhances the construction-themed experience. We can also assist with special requests to meet your unique needs. Imagine how a simple sign can transform and elevate the entire experience.

OPTIONS
page 30



Signs

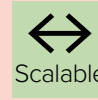

Scalable



BIM

Please note that measurements are approximate, models may vary from pictures, and colors may differ from images. We recommend verifying the specifics of the product you are interested in.

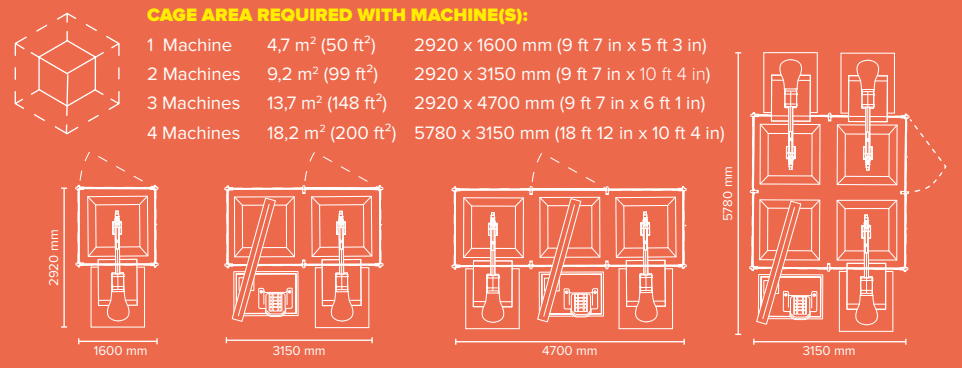

Construction Zone



DIGGER/GRABBER

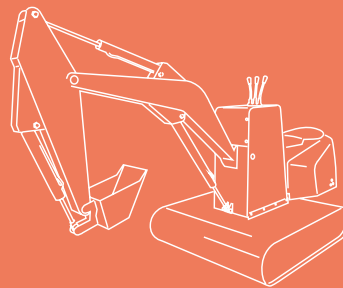

MEASUREMENT:

L 2400 mm, W 760 mm, (platform)
H 1000 mm.

TOTAL WEIGHT:

Approx. 92 kg.

TECHNICAL SPECIFICATIONS Digger / Grabber

- Capacity: 1 child.
- Age to operate: From 3 years (under adult supervision).
- Maximum weight admitted: 80 kg (180 lb).
- Body: Steel, powder coated.
- Seat: RTM fiberglass.
- Maximum noise: 65 dB.
- Timer: Adjustable, 3 or 5 minutes.
- Turning angle of arm: 90°.
- Recommended digging depth: 40 cm from digger base.
(Version with lower digging depth for indoor use available.)
- Electrical system: 230 VAC / 24 VDC,
US/Japan version 115 VAC / 24 VDC.
- Hydraulically operated: 3 cylinders,
a hydraulic control valve and oil pump system.
- Lever to operate:
 - Left lever: Boom (push/pull).
 - Middle lever: Shovel (push/pull).
 - Right lever: Arm (push/pull).
- Max amount of load in shovel: 3 liters (approx.).
- Oil pump: Pump is set at 20 bar and must not be
increased for safety reasons.
- Operating system: Coin/token mechanical coin acceptor or free
play button. Card payment or electronic multicoin acceptor as option.
- Security: To be installed with fence around digging area.
- Shipping parameters:
 - 1 unit 220 x 85 x 125 cm, 155 kg.
 - 2 units 220 x 85 x 210cm, 275 kg.

OPTIONS



AREA REQUIRED:

4,5 m² /pc (with platform)

CAPACITY / THRC (Per Unit)

Up to 12 rides per hour based on a
5 min ride cycle.

Construction Zone



TOWER CRANE

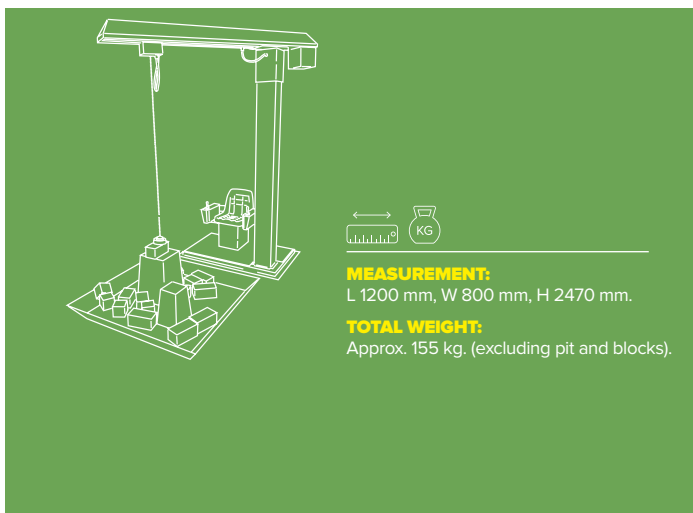

MEASUREMENT:
L 1200 mm, W 800 mm, H 2470 mm.

TOTAL WEIGHT:
Approx. 155 kg. (excluding pit and blocks).

TECHNICAL SPECIFICATIONS Tower Crane

- Capacity: 1 child.
- Age to operate: +3 age.
- Max. weight admitted: 80 kg (180 lb).
- Operating system: Coin mechanism (mechanical) or Push Button. Prewired for electronic coin acceptor or card payment system.
- Turning angle of boom: 60° (degrees). Custom changes available.
- Height of magnet: 120 cm from floor. (adjustable)
- Electrical system: Input 85-264 VAC. Operational 24 VDC, 60 W.
- Fuse: Power supply internal protections. short circuit/overload/over voltage. External, 2 A fuse.
- Timer: Adjustable to 3 or 5 minutes.
- Motors: 3 x 24 V DC motors.
- Electromagnet: Max capacity 1 kg (approx).
- Joysticks to Operate:
Right Joystick: Left/Right, Forward/Backward.
Left joystick: Up/Down. Release.
- Body: Powder coated steel.
- Shipping parameters:
1 unit 120 x 80 x 235 cm, 200 kg.

OPTIONS



AREA REQUIRED:
3,75 m² /pc

CAPACITY / THRC (Per Unit)
Up to 12 rides per hour based on a
5 min ride cycle.

Shopping Center

Rid in Style with Our Inflatable Car Tracks



- Excite Your Shopping Center
- Engage All Ages
- Prioritize Safety and Durability
- Flexible and Customizable
- Perfect for Events and Promotions
- Purchase or Rental Options Boost Foot Traffic and Satisfaction

Transform your shopping center into a hub of excitement with our Inflatable Car Tracks, designed for both indoor and outdoor spaces.

These tracks are engineered to transform ordinary shopping trips into thrilling adventures, drawing in visitors of all ages and keeping them engaged longer. Our Inflatable Car Tracks are not only versatile, accommodating various types of vehicles, but they also prioritize safety. Crafted from high-quality, durable materials, these tracks ensure smooth, enjoyable, and safe rides every time, offering a flexible solution for enhancing your retail environment.

Whether you're planning special events, seasonal promotions, or simply want to add a lively, festive element to your shopping center, our Inflatable Car Tracks are the ideal choice. With standard models available and options for customization, you can tailor the experience to perfectly fit your space and theme. Available for both purchase and rental, they offer flexible options to suit your needs and budget.

Invest in our Inflatable Car Tracks and turn your shopping center into a destination that people talk about and return to time and time again. Whether you choose to buy or rent, you're guaranteed a unique, safe, and customizable attraction that boosts foot traffic and customer satisfaction.

Many standard set-ups available" "Customization possible"



CAPACITY / THRC (Per Setup)
Up to 72 rides per hour based on a 5 min ride cycle

Vehicle Parking

We got the Vehicles

Durable material for heavy use

Plan for success

Partner Setup

We want to make the most out of the setup and therefore location is key. We know from experience that our attractions draw attention and are really appreciated and the location is key for success.

Strategically placed in central locations to ensure maximum visibility, our installations are protected from the elements, offering an enjoyable experience regardless of weather conditions. By keeping guests entertained, our attractions encourage longer visits, enhancing overall foot traffic and dwell time. With our standard revenue share model the venue will have 15% on all revenues. We collaborate with a local partner to guarantee smooth installation and operation, ensuring a hassle-free integration into your venue.

Target Audience: Families with children and general visitors
Location: High-traffic malls and similar venues
Benefit: Engages visitors and encourages longer stays
Placement: Central location to maximize exposure
Protection: Indoor or covered to shield from sun and rain
Revenue Share: Standard 15%
Local Support: Partner available for seamless integration

Visitor Flow and Safety

We understand that many parameters have to be met at each venue. We'd love to discuss these with you and together plan for exceptional results.

Effective management of visitor flow is essential for ensuring safety and enhancing the shopping experience. Properly distributing visitors throughout the shopping center helps prevent overcrowding and improves overall safety.

Visitor Flow: Strategic management of guest movement avoids congestion and ensures smooth access to stores and amenities.

Safety Measures: Effective flow management reduces risks and ensures that emergency exits and safety features are easily accessible.

Capacity Control: Monitoring the number of visitors helps maintain a comfortable and secure environment.

Strategic Placement: Thoughtful placement of stores and amenities promotes balanced visitor distribution and reduces bottlenecks.



◀ Example from the facility in operation at Asecs shopping center in Sweden.



Contact

SB International AB
Verktgsvägen 1
553 02 Jönköping
Sweden

+46 36 37 50 30

www.sbisweden.com
info@sbisweden.com



sbisweden.com