

Cage System

Fully customizable with a range of theming options to perfectly fit your location.

- Black PPA571 / Powder Coated.
- Easy to mount.
- Perfect for Mini Tower Crane and Mini Digger / Grabber.
- The swing radius of the Mini Digger / Grabber is adjusted to fit in the cage.
- Heavy duty adjustable platforms with LED Neon lights.

This safety cage allows machinery to operate safely with minimal supervision, meeting all regulatory standards. It enhances the "Construction Zone" look and offers space for signage, perfect for messages or promotions.



CUSTOMIZE YOUR ATTRACTION:

SIGNS: Custom decors on request	COLOR: ● Black Custom colors on request	OPTIONS: Customization possible
---	--	---

DESIGN YOUR CONSTRUCTION ZONE LAYOUT:

We assist in creating your perfect space-efficient layout.



Cage System

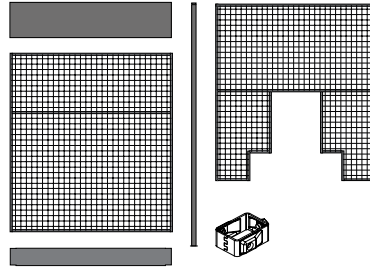
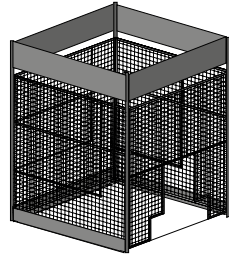

TECHNICAL SPECIFICATIONS

Fully customizable with a range of theming options to perfectly fit your location.

Steel Construction: Powder coated, black PPA571.

For one (1) item (without machine):

Length: 1600 mm, 5' 3".

Width: 1640 mm, 5' 5".

Height: 2200 mm, 7' 3".

Easy to mount.

Perfect for Mini Tower Crane and Mini Digger / Grabber.

The swing radius of the Mini Digger / Grabber is adjusted to fit in the cage.

Custom Theming.

Signs Kit.

AREA

Recommended minimum area: 1 Machine: 4,7 m² (50 ft²)

CERTIFICATES

Quality: ISO 9001, ISO 14001. CE marking.

3D / BIM (Building Information Modeling)

Revit and DWG models are available.

This safety cage is specifically engineered to allow machinery to operate safely without requiring constant staff supervision. It adheres to all relevant regulatory standards, ensuring the highest level of protection. Beyond its functional benefits, the cage is designed to enhance the "Construction Zone" atmosphere, adding an authentic industrial feel to the environment. The structure also provides ample space for signage, making it an ideal platform for displaying important messages or promotional content—seamlessly integrating safety with effective communication.

Enhance the Experience with Custom Signage

To elevate the visual impact, we offer signage that enhances the construction-themed experience. We can also accommodate special requests to meet your unique needs. Imagine how a simple sign can transform and elevate the entire experience. You can customize the signs and bottom plates with your own design, and plastic signs can be easily attached to the grid.

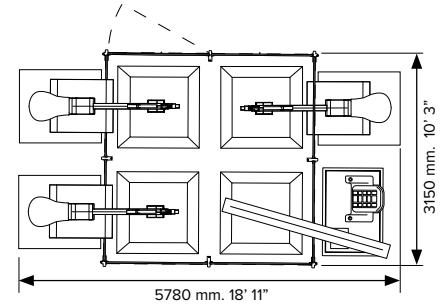

CAGE AREA REQUIRED WITH MACHINE(S):

1 Machine: 4.7 m², 50 ft²

1600 x 2920 mm. 5' 3" x 9' 7"

2 Machines: 9.2 m², 99 ft²

3150 x 2920 mm. 10' 4" x 9' 7"

3 Machines: 13.7 m², 148 ft²

4700 x 2920 mm. 15' 5" x 9' 7"

4 Machines: 18.2 m², 200 ft²

3150 x 5780 mm. 10' 4" x 19'

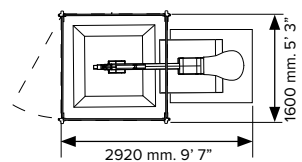
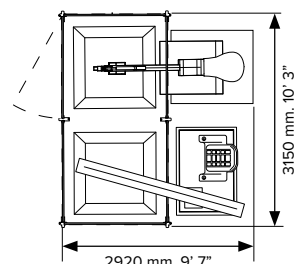
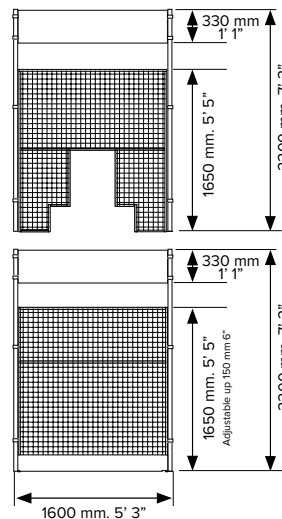
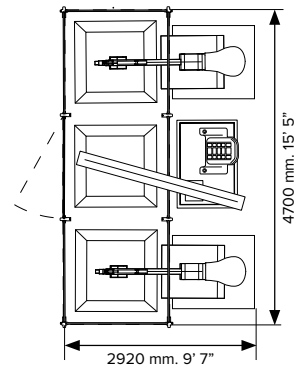

Scan to visit the productpage:

<https://sbisweden.com/concepts-and-products/construction-zone/>

