

F1S RACING

Our racing vehicle is perfect for car-themed parks, racing tracks and go-cart facilities for young kids.

- Capacity: 1 child
- Age range: from 3 to 11 years old
- Max. weight admitted: 50 kg (110 lbs)
- Fixed speed: 5 km/h (2,5 mph)
- Operating time: 8 – 10 hours per battery charge



CUSTOMIZE YOUR VEHICLES:

DECOR:

- Yellow
- Blue

Custom decors on request

COLOR:

- Red
- Yellow
- Green
- Blue
- Black

Custom colors on request

OPTIONS:

- 🔊 Sound
- 💡 Light
- ⚠️ Safety belt
- 📶 Remote on/off
- 🔄 Coin/Token

DESIGN YOUR TRACK LAYOUT:

We assist in creating your perfect space-efficient layout.

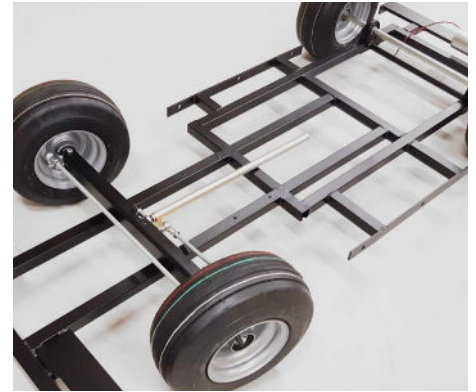
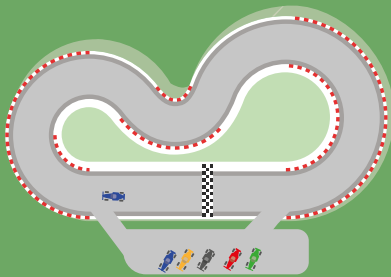

RECOMMENDED MINIMUM AREA:

20 m², 215 ft² per vehicle.

CAPACITY / THRC (example with 10 vehicles)

Up to 120 rides per hour based on a 5 min ride cycle. (10 vehicles minimum 200 m², 2152 ft².)



Racing Cars

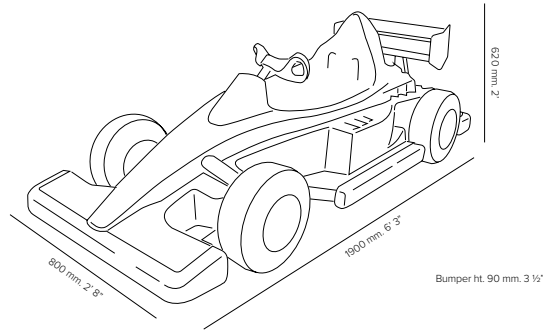

TECHNICAL SPECIFICATIONS

Authentic, durable design that fits seamlessly into any setup.
 Powered by a 12 V system.

FEATURES

- Capacity:** 1 child.
- Age range:** 3 to 11 years old.
- Maximum weight admitted:** 70 kg, 154 lb.
- Speed max:** 5 km/h, 3,11 mph.
- Length:** 1900 mm, 6 ft 3 in.
- Width:** 800 mm, 2 ft 8 in.
- Height:** 620 mm, 2 ft.
- Vehicle weight:** Approx. 96 kg, 209 lb. (incl. battery)
- Turning radius:** Outer dia. 900 cm. 16' 5".

- Frame:** Reinforced steel tubing, powder coated.
- Body:** Hand-laid GRP. 3-layer gelcoat, 3-layer mat and reinforced by laminate.
- Bodycolors:** Red, Yellow, Green, Blue, Black.
- Bumpers:** Molded vulcanized rubber with steel reinforcement.
- Transmission:** Belt.
- Wheels:** Rubber tire with inner tube. (13"). Ball Bearings in each rim.

- Electrical system:** 12 V. Available with 24 V system as option.
- Motor:** Electric motor with planetary gear.
- Motor fuse:** Automatic 12 V 10/12 A, 5 – 10 sec o, 10 – 20 sec reset.
- Battery:** Dry fit traction block (12 V – 50 Ah).
- Battery weight:** approx. 18 kg, 40 lb.
- Operating time:** 8 – 10 hours.
- Battery charger:** 3-step charger (12 V – 10 A), fully automatic.
- Accelerator:** Pedal (green), with micro switch.
- Brake:** Automatic.

- Shipping parameters:**
- 1 units: 190 x 90 x 80 cm. 6' 3" x 3' 0" x 2' 7" Approx. 150 kg. 330 lb
 - 2 units: 190 x 90 x 150 cm. 6' 3" x 3' 0" x 4' 11" Approx. 280 kg. 617 lb

NOTE
 To emphasize that the vehicles meet high safety standards, all products are clearly labeled with the requirements users should be aware of to ensure compliance with these standards.



SET-UP AND OPTIONS

PRODUCT	INCLUDED	OPTIONAL
Free Drive Setup	•	
Regular Gel Battery	•	
Battery Charger	•	
Seat Belt	•	
Decor: Racing. number logos and stripes		•
Lithium Battery System		•
Card Reader		•
R/C On/Off		•
Custom body colors		•
Custom Theming		•
Full Customization		•

AREA

Recommended minimum area: 20 m², 215 ft² per vehicle.
 (10 vehicles minimum area required 200 m², 2152 ft².)

CAPACITY / THRC

(Example with 10 vehicles) Up to 120 rides per hour based on a 5 min ride cycle.

CERTIFICATES

Quality: ISO 9001, ISO 14001. CE marking.



Scan to visit the productpage:

<https://sbisweden.com/concepts-and-products/racing-academy-racing-cars/>

