

Mini DIGGER Mini GRABBER

Hydraulically operated for a realistic experience; stationary design for maximum space efficiency.

- Capacity: 1 child.
- Age to operate: From 3 years (under adult supervision).
- Maximum weight admitted: 80 kg (180 lbs).
in color and decoration.
- Electro-zinc and powder coated for enhanced corrosion resistance.



CUSTOMIZE YOUR ATTRACTION:

| | | |
|---|--|--|
| <p>DECOR: Custom decors on request</p> | <p>COLOR: ● Yellow Custom colors on request</p> | <p>OPTIONS:</p> <ul style="list-style-type: none"> ● Sound ● Light ● Coin/Token/Card |
|---|--|--|

DESIGN YOUR CONSTRUCTION ZONE LAYOUT:

We assist in creating your perfect space-efficient layout.



| | | |
|--|---|---|
| | <p>AREA REQUIRED: 4,5 m², 49 ft² /pc (with platform)</p> | <p>CAPACITY / THRC (Per Unit) Up to 12 rides per hour based on a 5 min ride cycle.</p> |
|--|---|---|



Mini Digger & Mini Grabber

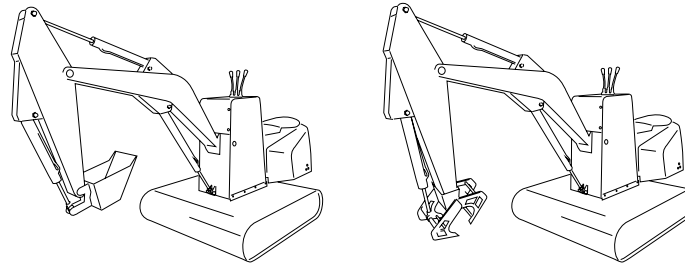

TECHNICAL SPECIFICATIONS

Kids love the authentic experience of operating these machines. Hydraulically operated for an authentic experience. Stationary, thus space efficient.

FEATURES

Capacity: 1 child.

Age to operate: From 3 years (under adult supervision).

Maximum weight admitted: 80 kg, 176 lb.

Length: 2400 mm, 7'10".

Width: 760 mm, 2'6" (platform)

Height: 1000 mm, 3'3" (platform 140 mm, 5.5")

Total Weight: Approx 92 kg, 203 lb.

Body: Electro zinc-plated, powder coated.

Seat: RTM fiberglass.

Color: Maize Yellow RAL 1006 / Slate Grey RAL 7015

Maximum noise: 65 dB.

Timer: Adjustable, 3 or 5 minutes.

Turning angle of arm: up to 90°.

Recommended digging depth: 35 cm, 1' 4" from digger base.

(Version with lower digging depth for indoor use available.)

Electrical system: 230 VAC / 24 VDC, US/Japan version 115 VAC / 24 VDC.

Hydraulically operated: 3 cylinders, a hydraulic control valve and oil pump system.

Lever to operate:

Left lever (red): Boom (push/pull).

Middle lever (blue): Shovel or grabb. (push/pull).

Right lever (yellow): Arm (push/pull).

Max amount of load in shovel: Approx 3 liters, 0.35 gal.

Oil pump: Pump is set at 20 bar.

Operating system: Standard: Button, (play free).

Card payment or electronic multicoin acceptor as option.

Safety: To be installed with fence around digging area.

Shipping parameters:

2 units: 226 x 80 x 200 cm, 7'2" x 2' 7" x 4'1". 220 kg, 485 lb.

2 units + Cage: 226 x 120 x 200 cm, 7'5" x 3' 11" x 6' 7". 520 kg, 926 lb.

NOTE

To emphasize that the vehicles meet high safety standards, all products are clearly labeled with the requirements users should be aware of to ensure compliance with these standards.

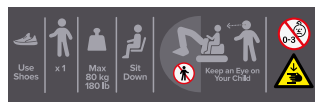

SET-UP AND OPTIONS

| PRODUCT | INCLUDED | OPTIONAL |
|--------------------------|----------|----------|
| Free Drive Setup | • | |
| Decor: Volvo Theme | • | |
| Coin / Token Operation | | • |
| Card Reader | | • |
| Electronic coin acceptor | | • |
| LED Lights & Sounds | | • |
| Custom body colors | | • |
| Custom Theming | | • |
| Full Customization | | • |
| Custom decor | | • |

AREA

Minimum area required 4,5 m², 49 ft².

CAPACITY / THRC

Up to 12 rides per hour based on a 5 min ride cycle.

CERTIFICATES

Quality: ISO 9001, ISO 14001. CE marking.

3D / BIM (Building Information Modeling)

Revit and DWG models are available.

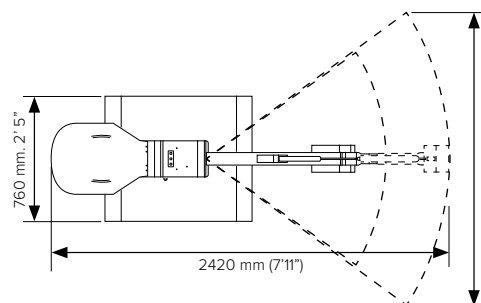

NOTE:
 The Digger/Grabber can be altered for swing and digging depth.

Scan to visit the productpage:

<https://sbisweden.com/concepts-and-products/construction-zone/>

